

MODELING OF THE FREE-SURFACE SHAPE IN LASER CUTTING OF METALS.

2. MODEL OF MULTIPLE REFLECTION AND ABSORPTION OF RADIATION

O. B. Kovalev and A. V. Zaitsev

UDC 621.378:535:539.375

A physical model of multiple reflection of focused laser radiation propagating in narrow channels and slots is proposed to be applied in laser treatment of metals. Based on the laws of geometric optics, an algorithm for calculating the shape of the surface formed by interaction of laser radiation and metal with the use of the trajectory technique is proposed. The method used allows one to describe energy transfer inward the channel in simulation of laser-treatment processes (drilling, cutting, and welding). It is shown that the efficiency of multiple reflection is most significant in cutting thick materials with a large ratio of the plate thickness to the Gaussian beam width.

Key words: radiation, laser treatment, multiple reflection, mathematical simulation.

Introduction. Advanced methods of simulating interaction of powerful laser beams with metals are based on the assumption that only single absorption of radiation is taken into account [1–3]. It is assumed thereby that the reflected radiation does not contribute significantly to material failure and dissipates in metal due to heat conduction. Visual observations of real processes of laser treatment [4] show that there occurs multiple reflection of radiation propagating inside the laser cut or cavity, especially, in the case of thick materials (with thickness $h \geq 10$ mm).

The issues of simulating multiple reflection of radiation have been already discussed (see, e.g., [5–8]). The models and methods proposed, however, are not self-consistent because they are based on integral conservation laws written for a prescribed cut shape unchanged in time.

Formulation of the Problem. It is known that focused laser radiation propagates in the form of electromagnetic oscillations and has the shape of a Gaussian beam corresponding to an approximate particular solution of the Maxwell equations [9]. Upon reflection of the Gaussian beam from an arbitrary surface, its shape can change significantly; in this case, wave properties of radiation are important. A correct formulation of the problem of interaction of electromagnetic radiation with an arbitrary metallic surface is complicated by the necessity of solving complete equations of electrodynamics. A simplified model and an algorithm described below allow one to estimate the degree of influence of multiple reflection and absorption of radiation on the surface shape obtained during laser drilling and cutting of metals.

The present formulation is based on the traditional statement of the problem [2, 3] in which the surface shape $z = z_m(x, y, t)$ is determined by solving the equation of kinematic compatibility of its points. The surface shape changes in time under the action of focused and permanently acting laser radiation. The normal component of the surface velocity V_n is determined by the ratio of the power density of radiation absorbed by a surface element Q to the energy spent on material failure:

$$V_n = Q / (\rho_m H_m + c_s^0 \rho_s^0 (T_m - T_0)), \quad Q = AI(x, y, z) \cos \gamma. \quad (1)$$

Here, x , y , and z are the spatial coordinates, ρ_m is the material density at the melting temperature T_m , H_m is the

Institute of Theoretical and Applied Mechanics, Siberian Division, Russian Academy of Sciences, Novosibirsk 630090; kovalev@itam.nsc.ru; zaitsev@gorodok.net. Translated from *Prikladnaya Mekhanika i Tekhnicheskaya Fizika*, Vol. 46, No. 1, pp. 16–20, January–February, 2005. Original article submitted September 29, 2003; revision submitted April 30, 2004.

specific heat of melting, ρ_s^0 and c_s^0 are the density and specific capacity of the material at the initial temperature T_0 , A is the absorption factor, $I(x, y, z)$ is the radiation intensity, and γ is the angle of beam incidence.

We consider circular polarization of the Gaussian beam, for which the radiation-absorption factor depends on the reflective properties of the material and spatial orientation of the plane of incidence [3]:

$$A_c = 1 - 0.5(R_S(1 - N_z^2) + R_P(1 + N_z^2)). \quad (2)$$

Here $R_S(\gamma)$ and $R_P(\gamma)$ are the reflection factors for the transverse (S) and longitudinal (P) radiation waves, N_z is the projection of the normal vector to the material surface onto the Oz axis.

The proposed physicomathematical model for calculating the surface shape, which takes into account multiple reflection of radiation, differs from the traditional model [3] by the fact that the normal component of the surface velocity V_n is expressed in terms of the sum of the entire multiply absorbed power Q at each point of the surface. The value of $Q(x, y, z_m(x, y, t))$ is calculated by the trajectory method, which implies that the distribution of intensity of the Gaussian beam is subjected to finite-element discretization. A domain whose size is two or three times greater than the beam diameter is chosen in the focal plane of the Gaussian beam of radius ω_0 . This domain is divided into finite elements of size $h_x \times h_y$ (h_x and h_y are the steps of discretization in the x and y directions, respectively). Each element is a light beam with coordinates x_{k_i} , y_{k_i} , and z_{k_i} containing the radiation energy $E_{k_i} = I(x_{k_i}, y_{k_i}, z_{k_i})h_x h_y$. The vector of beam displacement coincides with the wave vector \mathbf{k}_i .

Initially, the beams move along trajectories that coincide with the shape of the Gaussian beam. Interacting with the surface, the trajectory of each beam changes its direction by the laws of geometric optics (angle of incidence equals the angle of reflection). The energy transferred by the beam decreases by the value of energy absorbed by the metal surface. It is assumed that circular polarization of radiation is retained after reflection. Figure 1 shows the scheme of two reflections on the light beam from the free surface. The wave vectors of the incident \mathbf{k}_{0i} and reflected \mathbf{k}_{1i} radiation are located in one plane with the normal vector to the surface \mathbf{N}_1 and form the plane of incidence. The direction of reflected radiation \mathbf{k}_{1i} is determined from the vector relation $\mathbf{k}_{1i} = \mathbf{k}_{0i} - 2(\mathbf{N}_1, \mathbf{k}_{0i})\mathbf{N}_1$. The absorbed power $Q(x, y, z_m(x, y, t))$ is calculated as a matrix Q_{ij} . Thus, for two reflections shown in Fig. 1, we obtain

$$\begin{aligned} Q_{i1j1} &:= Q_{i1j1} + A_c(\gamma_1)E_{0i}, & E_{1i} &= E_{0i}(1 - A_c(\gamma_1)), & \mathbf{k}_{1i} &= \mathbf{k}_{0i} - 2(\mathbf{N}_1, \mathbf{k}_{0i})\mathbf{N}_1, \\ Q_{i2j2} &:= Q_{i2j2} + A_c(\gamma_2)E_{1i}, & E_{2i} &= E_{1i}(1 - A_c(\gamma_2)), & \mathbf{k}_{2i} &= \mathbf{k}_{1i} - 2(\mathbf{N}_2, \mathbf{k}_{1i})\mathbf{N}_2, \end{aligned}$$

where the sign $:=$ indicates assignment (after each reflection of the beam, the value of Q_{ij} increases by the value of absorbed energy).

The numerical algorithm implies smoothing of the resultant discrete function Q_{ij} . The coordinates of the points of intersection of the light-beam trajectory with the moving surface of the material are calculated by the method of surface approximation by Hermite cubic splines [10].

Calculation Results. Figure 2 shows the calculation results for interaction of the Gaussian beam in the channel of an orifice obtained by laser drilling of a steel plate of thickness $h = 1$ mm. The radiation power is $W = 1$ kW, the depth of the focus is $z_f = 0.25$ mm, and the radius of the focal plane of the beam is $\omega_0 = 100$ μm . Figure 3 shows the spatial pattern of propagation of the radiation beam in the cutting channel with the maximum cutting depth of the metal plate. The power is $W = 1$ kW, the cutting velocity is $V_c = 0.17$ m/sec, the depth of the focus is $z_f = 0.25$ mm, and the radius of the focal plane of the beam is $\omega_0 = 100$ μm . The horizontal level lines correspond to the contour of the resultant surface. It is seen that the light beams are multiply reflected from the inner surface of the channel. The total number of beams into which the initial beam was divided was approximately 10,000, and the figures show only the most typical beams.

For comparison, Fig. 4 shows the meridional sections of the orifice in the plane (x, z) without allowance for reflection (Fig. 4a and c) and with allowance for reflection (Fig. 4b and d). One can see that there are more reflections in drilling than in cutting. The shape of the orifice, however, remains unchanged because only peripheral beams with low energy are reflected. In the case of cutting with allowance for multiple reflection in the cutting front, the maximum cutting depth is much greater (Fig. 4d). The shapes of the resultant orifice and cut are in agreement with those observed in full-scale experiments performed on the laser technological setup for cutting and drilling of various materials [4].

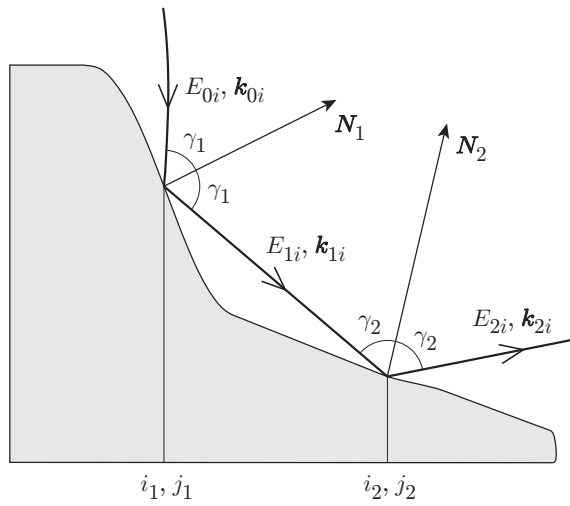

Fig. 1. Trajectory of motion of the light beam and scheme of its two reflections from the free surface.

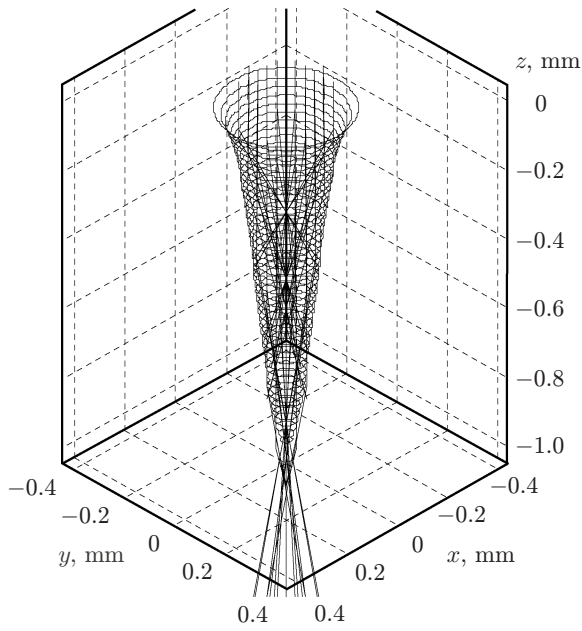

Fig. 2

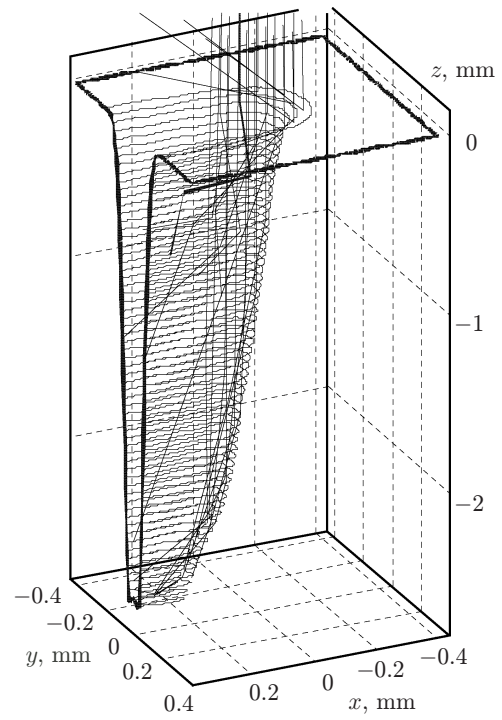

Fig. 3

Fig. 2. Propagation of radiation in the cavity in the case of laser drilling of metal.

Fig. 3. Propagation of radiation in the cutting channel in the case of laser cutting of metal.

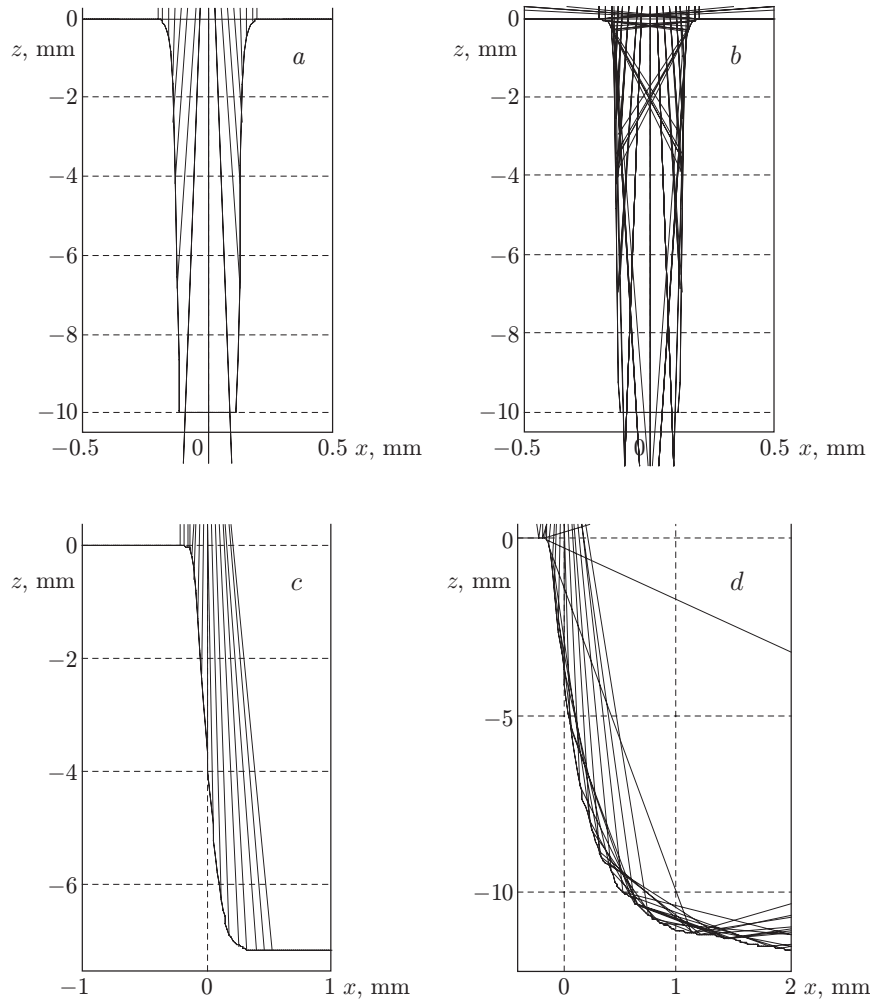

Fig. 4. Shape of the orifice (a and b) in the case of laser drilling and the cut shape (c and d) in the case of laser cutting without (a and c) and with (b and d) allowance for reflection.

Conclusions. Multiple reflection of laser radiation propagating in a narrow channel is theoretically considered. A physicomathematical model of three-dimensional interaction of laser radiation with metal is proposed, which takes into account multiple reflection of laser radiation. Based on the trajectory technique and on the laws of geometric optics, an algorithm and a code for calculating multiple reflection of radiation in narrow channels and slots are proposed to be applied in laser treatment of metals. It is shown that the influence of multiple reflection is more profoundly manifested in laser cutting, and the maximum cutting depth increases. The proposed model of multiple reflection takes into account the energy transfer inward the channel, which seems to be important in describing laser-treatment processes (drilling, cutting, and welding) for thick materials.

The algorithm developed should be considered as approximate because the wave properties of radiation are ignored after the first reflection of the Gaussian beam, though the numerical algorithm implying smoothing of the absorbed power partially compensates for this drawback of the physical model.

The authors are grateful to A. M. Orishich for formulating the problem and to V. M. Fomin for frequent discussions of results and valuable comments.

This work was supported by the Russian Foundation for Basic Research (Grant No. 04-01-00798).

REFERENCES

1. L. Cai and P. Sheng, "Analysis of laser evaporative and fusion cutting," *J. Manuf. Sci. Eng.*, **118**, 225–234 (1996).
2. V. G. Niziev and A. V. Nesterov, "Influence of beam polarization on laser cutting efficiency," *J. Phys. D, Appl. Phys.*, **32**, 1455–1461 (1999).
3. O. B. Kovalev and A. V. Zaitsev, "Modeling of the free-surface shape in laser cutting of metals. 1. Effect of polarization of the Gaussian beam on the shape of the surface formed," *J. Appl. Mech. Tech. Phys.*, **45**, No. 6, 915–921 (2004).
4. A. N. Malov, N. A. Malov, A. M. Orishich, and V. B. Shulyat'ev, "Cutting of thick metallic plates by radiation of a CO₂ laser with a self-filtered resonator," in: *Laser Technologies and Their Implementation*, Proc. IV Int. Conf. (St. Petersburg, September 24–26, 2003), Izd. St. Petersburg. Politekh. Univ., St. Petersburg (2004), pp. 39–46.
5. K. Minamida, H. Takaafuji, N. Hamada, et al., "Wedge shape welding with multiple reflecting effect of high power CO₂-laser beam," in: C. M. Banas and G. L. Whitney (eds.), *The Changing Frontiers of Laser Materials Processing*, IFS, UK (1986), pp. 97–104.
6. J. Milewski and E. Sklar, "Modeling and validation of multiple reflections for enhanced laser welding," *Model. Simul. Mater. Sci. Eng.*, **4**, 305–322 (1996).
7. J. Duan, H. C. Man, and T. M. Yue, "Modeling the laser fusion cutting process. 1. Mathematical modeling of the cut kerf geometry for laser fusion cutting of thick metal," *J. Phys. D, Appl. Phys.*, **34**, 2127–2134 (2001).
8. A. Kaplan, "A model of deep penetration laser welding based on calculation of the keyhole profile," *J. Phys. D, Appl. Phys.*, **27**, 1805–1814 (1994).
9. A. N. Oraevskii, "Gaussian beams and optical resonators," *Tr. Fiz. Inst. Lebedev*, **187**, 3–59 (1988).
10. Yu. S. Zav'yalov, B. I. Kvasov, and V. L. Miroshnichenko, *Methods of Spline Functions* [in Russian], Nauka, Moscow (1980).